

EXTECH[®]

USER MANUAL

600 A True RMS Digital Clamp Meter

MODEL EX655

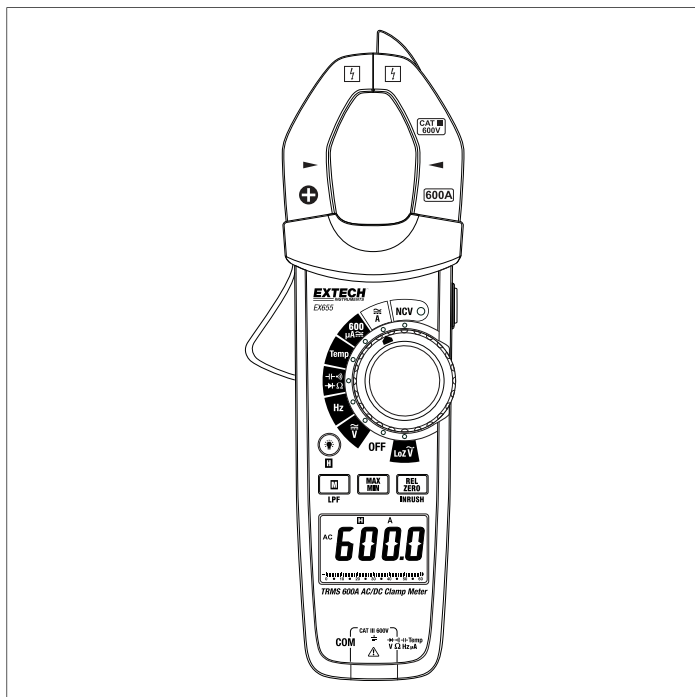

Table of contents

1	Advisories	1
1.1	Copyright.....	1
1.2	Quality Assurance	1
1.3	Documentation	1
1.4	Disposal of Electronic Waste	1
2	Introduction	2
3	Features	3
4	Safety	4
4.1	Voltage Alert.....	5
5	Product Description	6
5.1	Meter Description	6
5.2	Display Description	7
5.3	Function Switch Description	7
5.4	Button Descriptions.....	8
5.4.1	MODE and Low Pass Filter Button	8
5.4.2	Relative (Zero) and Inrush Button	8
5.4.3	MAX-MIN Button.....	8
5.4.4	Backlight and Data Hold Button.....	9
5.4.5	Worklight Button	9
6	Meter Power	10
6.1	Battery Power	10
6.2	Automatic Power OFF (APO).....	10
7	Measurements	11
7.1	Measurement Safety and Preparation	11
7.2	Current Measurements (Clamp).....	12
7.3	Current Measurements (Inrush)	15
7.4	Micro Amp Current Measurements (Test Leads).....	16
7.5	Voltage Measurements	18
7.6	Voltage Measurements (Low Impedance)	21
7.7	Resistance and Continuity Measurements.....	22
7.8	Capacitance Measurements	25
7.9	Electronic Frequency Measurements	27
7.10	Temperature Measurements	29
7.11	Non-Contact Voltage Detection.....	31
7.12	Diode Testing.....	33
7.13	Relative (Zero) Mode.....	35

Table of contents

	7.14	MAX-MIN Measurement Capture	36
8		Maintenance	37
	8.1	Battery Replacement	37
	8.2	Cleaning and Storage	38
9		Specifications	39
	9.1	General Specifications	39
	9.2	Measurement Specifications	40
10		Customer Support	43
11		Limited 3-Year Warranty	44

1 Advisories

1.1 Copyright

©2025 FLIR Systems, Inc. All rights reserved worldwide.

No parts of the software including source code may be reproduced, transmitted, transcribed or translated into any language or computer language in any form or by any means, electronic, magnetic, optical, manual or otherwise, without the prior written permission of FLIR.

The documentation must not, in whole or part, be copied, photocopied, reproduced, translated or transmitted to any electronic medium or machine-readable form without prior consent, in writing, from FLIR Systems, Inc. Names and marks appearing on the products herein are either registered trademarks or trademarks of FLIR Systems, Inc. and/or its subsidiaries. All other trademarks, trade names or company names referenced herein are used for identification only and are the property of their respective owners.

1.2 Quality Assurance

The Quality Management System under which these products are developed and manufactured has been certified in accordance with the ISO 9001 standard. FLIR Systems, Inc. is committed to a policy of continuous development; therefore, we reserve the right to make changes and improvements on any of the products without prior notice.

1.3 Documentation

To access the latest manuals and notifications, go to the Download tab at: <https://support.flir.com>. It only takes a few minutes to register online. In the download area you will also find the latest releases of manuals for our other products, as well as manuals for our historical and obsolete products.

1.4 Disposal of Electronic Waste



As with most electronic products, this equipment must be disposed of in an environmentally friendly way, and in accordance with existing regulations for electronic waste. Please contact your FLIR representative for more details.

2 Introduction

Thank you for selecting the Extech Model EX655 true RMS clamp meter. The EX655 measures AC/DC voltage and current, resistance, capacitance, temperature, and frequency. It also tests diodes, continuity, inrush current, and includes a non-contact voltage detector.

This device is shipped fully tested and calibrated and, with proper use, will provide years of reliable service. Please visit the Extech website to check for the latest version of this user manual and for customer support.

3 Features

- Backlit 6000 count digital display with 60 segment analog bar graph
- True RMS AC measurements
- 600 A AC and DC current measurements (clamp)
- 600 μ A AC and DC current measurements (test leads)
- Meter and supplied test leads are rated CAT III 600 V
- Temperature measurements
- Non-contact voltage detector
- Visual and audible continuity measurement alert
- Inrush current capture
- Low impedance mode helps identify 'ghost' voltages
- Low pass filter removes high frequency noise from measurements
- 0.5% DCV accuracy
- Automatic ranging
- Data Hold
- Relative (zero) mode
- Auto Power OFF (APO)
- Low battery indicator
- Includes test leads, Type-K temperature probe, and batteries

4 Safety

To ensure the safe operation and service of this meter, follow all safety instructions carefully. Failure to observe warnings can result in severe injury or death.

	WARNING
<p>Warnings identify hazardous conditions and actions that could cause serious injury or death.</p> <ul style="list-style-type: none">• When handling test leads or probes, always keep hands and fingers behind the finger guards. To avoid electric shock do not touch exposed electrical wires, connectors, unused input terminals, or circuits under test.• Remove test leads from the meter before opening the battery compartment or housing.• Use the meter only as specified in this user manual to ensure the integrity of the protections provided by the meter.• Be sure to use the proper input terminals and function switch position when taking measurements.• Verify proper meter operation by measuring a known voltage. Contact customer support if the meter responds unusually or if you need assistance.• Do not apply more than the rated voltage, as marked on the meter, between terminals or between any terminal and earth ground.• Do not measure voltage > 600 V AC or DC between terminals and ground, to prevent electrical shock and meter damage.• Use caution when working with voltages > 30 V AC RMS, 42 V AC peak, or 60 V DC. These voltages pose a shock hazard.• Replace the batteries as soon as the low battery indicator is displayed, to avoid erroneous readings that could result in electric shock and injury.• Disconnect power to the circuit under test, and discharge all high voltage capacitors, before testing resistance, continuity, diodes, or capacitance.• Do not use the meter in the presence of explosive gas or vapour.• To reduce risk of fire or electrical shock, do not use the meter if it is wet and do not expose the meter to moisture.• Personal protective equipment should be used if hazardous live parts, in the installation where measurements are to be made, are accessible.	











	CAUTION
<p>Cautions identify conditions and actions that could cause damage to the meter or equipment under test.</p> <ul style="list-style-type: none">• Disconnect the test leads from the test points before changing the position of the function (rotary) switch.• Do not expose the meter to extremes in temperature or humidity.• Never set the meter to the resistance, diode, capacitance, or current functions when measuring the voltage of a power supply circuit; this could result in damage to the meter and/or equipment under test.	

Table 4.1 Safety Symbols

	This symbol, adjacent to another symbol, indicates that the user must refer to the user manual for further information
	Risk of electrical shock
	Fuse
	Equipment protected by double or reinforced insulation
	Low battery
	Conforms to EU directives
	AC measurements
	DC measurements
	Earth ground

4.1 Voltage Alert

If the meter detects a voltage of 30 V, or higher, or a voltage overload (OL) condition in the voltage mode (including the low impedance mode), this warning symbol  is displayed.

5 Product Description

5.1 Meter Description

1. Non-contact voltage detector (NCV)
2. Clamp jaws
3. Polarity indicator (current flowing through the clamp jaws, from front to back, are of positive polarity)
4. Jaw opening trigger
5. Backlight and Data Hold button
6. Mode and Low Pass Filter button
7. NCV alert lamp
8. Worklight button
9. Function switch
10. Relative (zero) and inrush current button
11. MAX-MIN button
12. Backlit LCD
13. Common (ground) input terminal
14. Positive input terminal

Battery compartment is on back of meter, see Section 8.1 for battery replacement instructions.

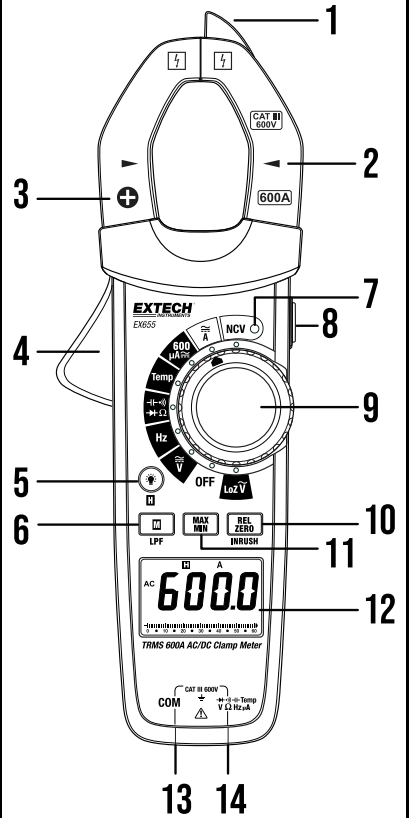

5.2 Display Description

<ol style="list-style-type: none"> 1. High voltage 2. Low battery 3. Relative (zero) mode 4. Auto power off (APO) enabled 5. Data hold 6. Measurement units 7. Direct current 8. Alternating current 9. Diode mode 10. Continuity mode 11. Automatic range 12. Low impedance mode 13. Inrush current 14. Maximum and Minimum readings 15. Non-contact voltage detector mode 16. Low pass filter 17. Temperature measurement units 18. Bar graph 	
---	--

5.3 Function Switch Description

<ol style="list-style-type: none"> 1. Low impedance mode 2. Meter power OFF 3. Voltage AC and DC, and electrical frequency 4. Electronic frequency 5. Capacitance, continuity, diode, resistance modes 6. Temperature mode 7. 600 μA current mode (test leads) 8. 600 A current mode (clamp) 9. Non-contact voltage detector mode 	
---	--

5.4 Button Descriptions

5.4.1 *MODE and Low Pass Filter Button*



LPF

Short press the Mode button to perform the functions listed in the table below. Long press the button to switch ON/OFF the low pass filter (LPF).

Switch positions	Mode button function
\approx V	Step through AC, Hz, and DC
\approx A 600 $\mu\text{A} \approx$	Toggle AC and DC
$\rightarrow \rightarrow \rightarrow$ $\rightarrow \rightarrow \Omega$	Step through Resistance, Continuity, Diode, and Capacitance
TEMP	Toggle °C and °F

5.4.2 *Relative (Zero) and Inrush Button*



INRUSH

Use the relative mode to zero the display and to compare measurements with a stored reference value. See Section 7.13 for instructions.

Short press to switch ON/OFF the Relative mode (in DC voltage, AC Current, Resistance, and Capacitance modes). In Relative mode, the delta symbol is displayed Δ .

5.4.3 *MAX-MIN Button*



In MAX-MIN mode, the meter captures and displays the maximum and minimum readings, updating the readings only when higher or lower values are registered.

This mode is available in the Voltage (AC and DC), Current (AC and DC), Resistance, and Temperature modes.

1. Press the MAX MIN button to start recording.
2. The **MAX** icon will appear and the displayed reading will represent the highest reading.
3. Press the button again. The **MIN** icon will appear and the displayed reading will represent the lowest reading.
4. Continue to use the button to toggle the MAX and MIN readings.
5. To exit this mode, and to reset the MAX MIN memories, long press the button (the **MAX** and **MIN** icons will switch OFF).

5.4.4 Backlight and Data Hold Button



Long press this button to switch ON/OFF the Data Hold function. In Data Hold mode the displayed reading is frozen and the **HOLD** icon is shown.

Short press to switch ON/OFF the backlight.

5.4.5 Worklight Button

The Worklight button is located on the right side of the meter.

Long press this button to switch ON the worklight. Short press to switch OFF.

6 Meter Power

6.1 Battery Power

The meter is powered by three (3) 1.5 V 'AAA' batteries (rear compartment).

Turn the function switch to any position to power the meter. When the battery needs to be replaced, the low battery indicator  will appear.

Turn the function switch to the OFF position, to switch OFF the meter.

Refer to Section 8, *Maintenance*, for instructions on battery replacement.

6.2 Automatic Power OFF (APO)

The meter switches off after 20 minutes of inactivity. Press the Mode button to reset the APO timer. The steps below explain how to disable the auto power OFF feature.

1. With the meter OFF, long press the Mode button while turning the function switch to any position.
2. The meter will beep twice to confirm that APO has been disabled, and the APO display icon will switch OFF.
3. Release the Mode button.
4. APO will be enabled again the next time meter power is cycled.

7 Measurements

 CAUTION
Read and observe all safety statements before use.

7.1 Measurement Safety and Preparation

 WARNING
<ul style="list-style-type: none">• Always use the test lead protective sleeves when making measurements.• Do not measure voltage > 600 V AC or DC.• The display shows a voltage alert icon ⚡ when the voltage measured is > 30 V AC. The meter will beep and show the warning icon when the voltage measurement is > 600 V AC or DC.

 CAUTION
When connecting test leads to the circuit under test, connect the black lead first, and then the red; when removing the test leads, remove the red test lead first and then the black lead.

NOTE

AC measurements use true RMS AC coupling. The specified accuracy for all waveforms, other than sine waves, must be adjusted as follows.

- Crest factor from 1 to 2; accuracy specification increases by 3%.
- Crest factor from 2 to 2.5; accuracy specification increases by 5%.
- Crest factor from 2.5 to 3; accuracy specification increases by 7%.

NOTE

For optimum accuracy, when measuring in the 600 mV range, zero the display before taking measurements. Short-circuit the probe input (to zero the display), press the Relative (zero) button to reset the display, press Relative again to exit the mode, and then take measurements. The delta symbol Δ is shown when the Relative mode is active.

7.2 Current Measurements (Clamp)



**WARNING**

Do not measure current on a circuit when the voltage is > 600 V AC or DC. This can damage the meter and cause serious injury to persons. Read all safety and preparation information in Sections 4 and 7.1 before proceeding.

NOTE

- The safe operating temperature for clamp measurements is 0 to 40°C (32 to 104°F).
- When using the clamp trigger, press and release it slowly. Releasing it suddenly can cause readings to fluctuate.
- If a DC current reading indicates positive polarity, the direction of current is from the front of the meter to the back (notice the '+' indication printed on the front of the clamp jaws).
- For optimum accuracy, conductors must be positioned in the middle of the clamp area.

Refer to Figures 7.1 and 7.2, below, for illustrated current clamp measurements.

1. Disconnect the test leads from the meter.
2. Set the function switch to the current position .
3. Use the Mode button to select AC or DC. For DC measurements, press the Relative (Zero) button to remove residual magnetism before taking a measurement, the delta symbol  will appear.
4. Press the trigger to open the clamp jaws and fully enclose only one conductor. Close the jaws, centring the conductor as close as possible for best accuracy.
5. Read the current measurement digitally and on the bar graph. The meter automatically selects the optimum range. For DC measurements, positive polarity is assumed and negative polarity is indicated.
6. For AC measurements, engage/disengage the low pass filter by long pressing the LPF button. When engaged, the **LPF** icon is shown. The low pass filter helps eliminate high frequency noise when measuring such devices as inverters and variable speed drives.
7. For inrush current measurements, refer to Section 7.3, below.

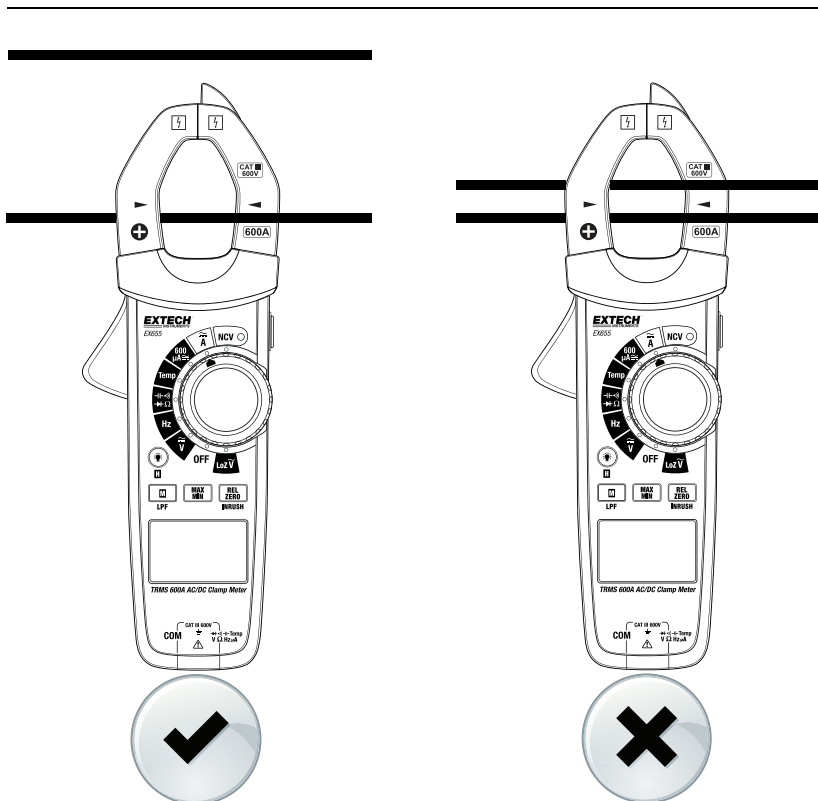

Figure 7.1 Correct (left) and incorrect (right) clamping. Clamp only one conductor.

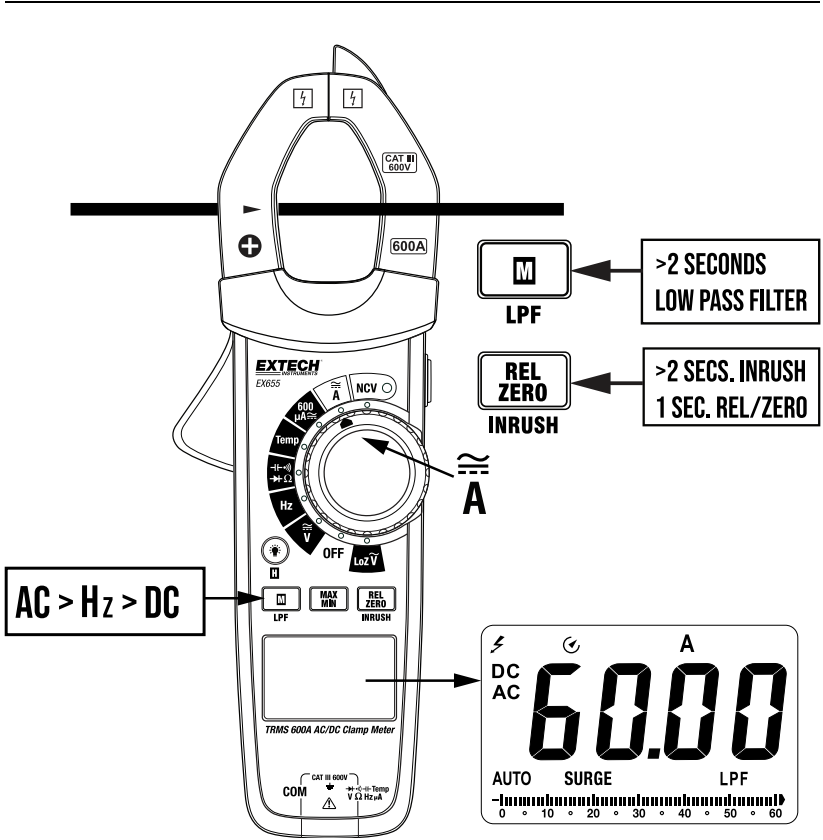

Figure 7.2 AC and DC Current Clamp Measurements

7.3 Current Measurements (Inrush)

In inrush mode, the meter displays the RMS AC current reading that represents the first 100 ms period after the trigger point (current detection threshold) is reached, see Figure 7.3, below. The current detection threshold is 5.0 A for the 600.0 A range.

Prepare an AC current measurement as described in Section 7.2, above, and continue with the steps below.

1. Remove power to the circuit under test and attach the clamp to one conductor.
2. Set the function switch to the current position and use the Mode button to select AC.
3. Long press the Inrush button, the display will briefly show the term **RUSH**.
4. **SURGE** will then be displayed on the lower area of the display.
5. Apply power to the circuit under test. When the threshold is reached, the display will show the RMS reading for the 100 ms integration time.
6. Long press the Inrush button to exit the mode (**SURGE** will switch OFF).

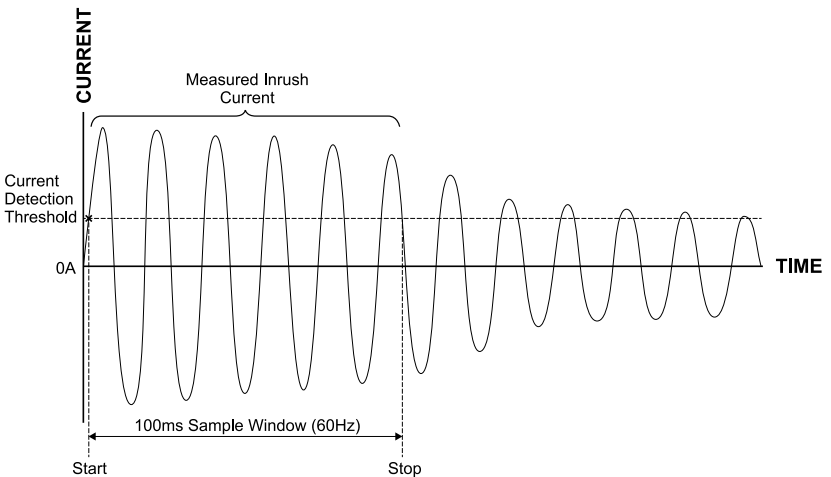

Figure 7.3 Inrush current action.

7.4 Micro Amp Current Measurements (Test Leads)

**WARNING**

Read all safety and preparation information in Sections 4 and 7.1 before proceeding.

Refer to Figure 7.4, below, for an illustrated test lead current measurement.

1. Insert the black test lead banana plug into the COM meter terminal. Insert the red test lead banana plug into the positive meter terminal.
2. Set the function switch to the 600 μA current position **600** μA .
3. Use the Mode button to select AC or DC.
4. Touch the test leads in series with the circuit under test. The red test lead should touch the positive side of the circuit and the black test lead the negative side of the circuit.
5. Read the current measurement digitally and on the bar graph. The meter automatically selects the optimum range. For DC measurements, positive polarity is assumed and negative polarity is indicated.

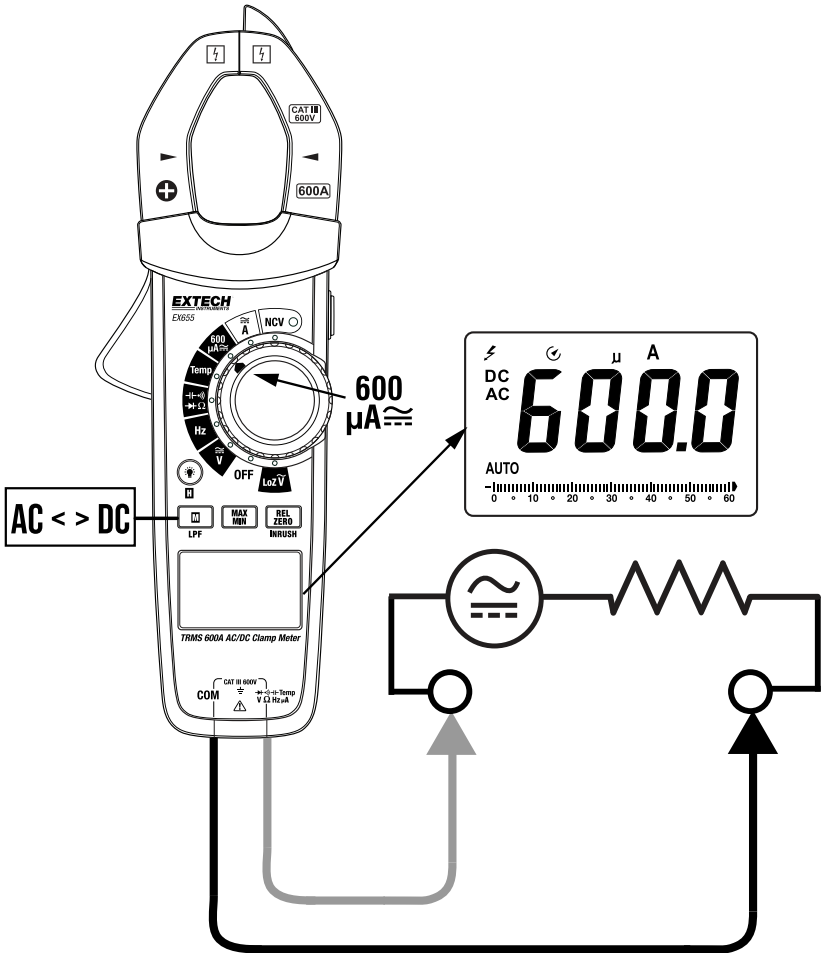

Figure 7.4 Micro amp current measurements using test leads.

7.5 Voltage Measurements

Read all safety and preparation information in Sections 4 and 7.1 before proceeding.

Refer to Figures 7.5 and 7.6, below, for illustrated voltage measurements.

1. Insert the black test lead banana plug into the COM meter terminal. Insert the red test lead banana plug into the positive meter terminal.
2. Set the function switch to the voltage \tilde{V} position. Alternatively, use the low impedance switch position **LoZ \tilde{V}** to lower the input impedance for AC voltage measurements to approximately 3 k Ω (to help identify 'ghost' voltages).
3. Use the Mode button to select AC or DC.
4. Touch the test lead tips to the circuit under test.
5. View the digital and analog bar graph readings on the display. The meter is capable of measuring up to 600 V AC and DC; the measurement range is automatically selected. The display also shows the measurement type, unit of measure, the voltage alert symbol ⚡ , and other relevant function icons.
6. For AC measurements, use the Mode button to step to the frequency (Hz) display.
7. For DC measurements, positive polarity is assumed and negative polarity is indicated.
8. For AC measurements, engage/disengage the low pass filter by long pressing the LPF button. When engaged, the **LPF** icon is shown. The low pass filter helps eliminate high frequency noise.

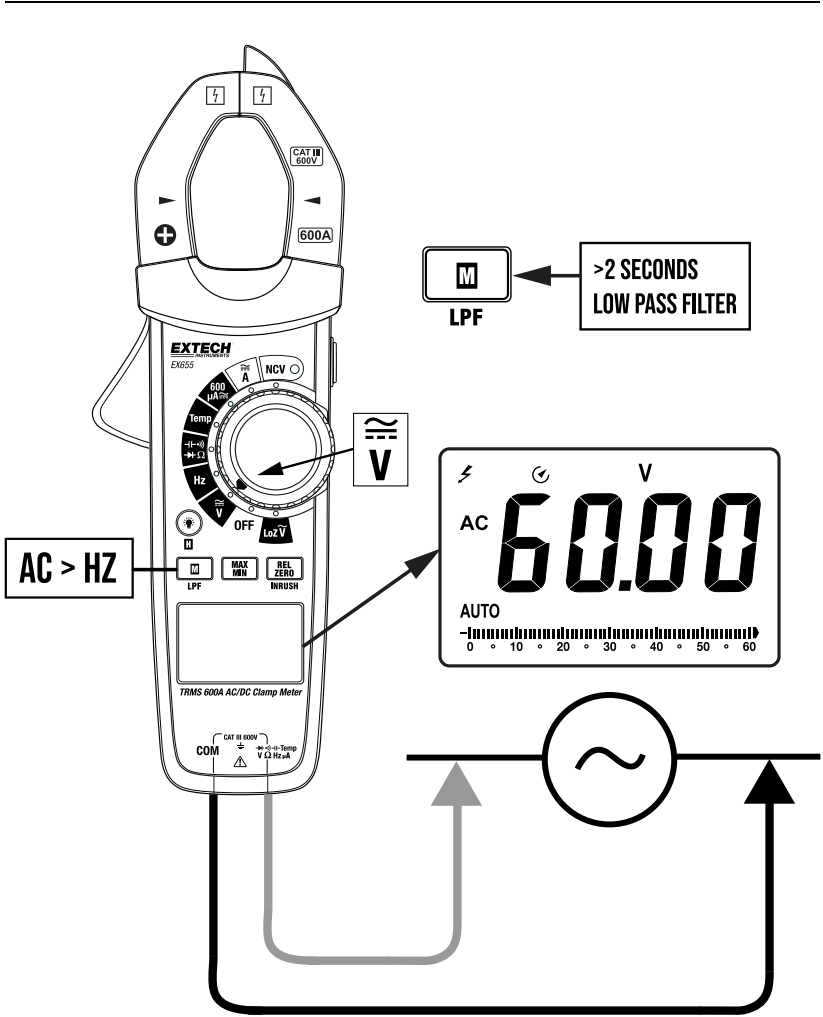

Figure 7.5 AC Voltage measurements.

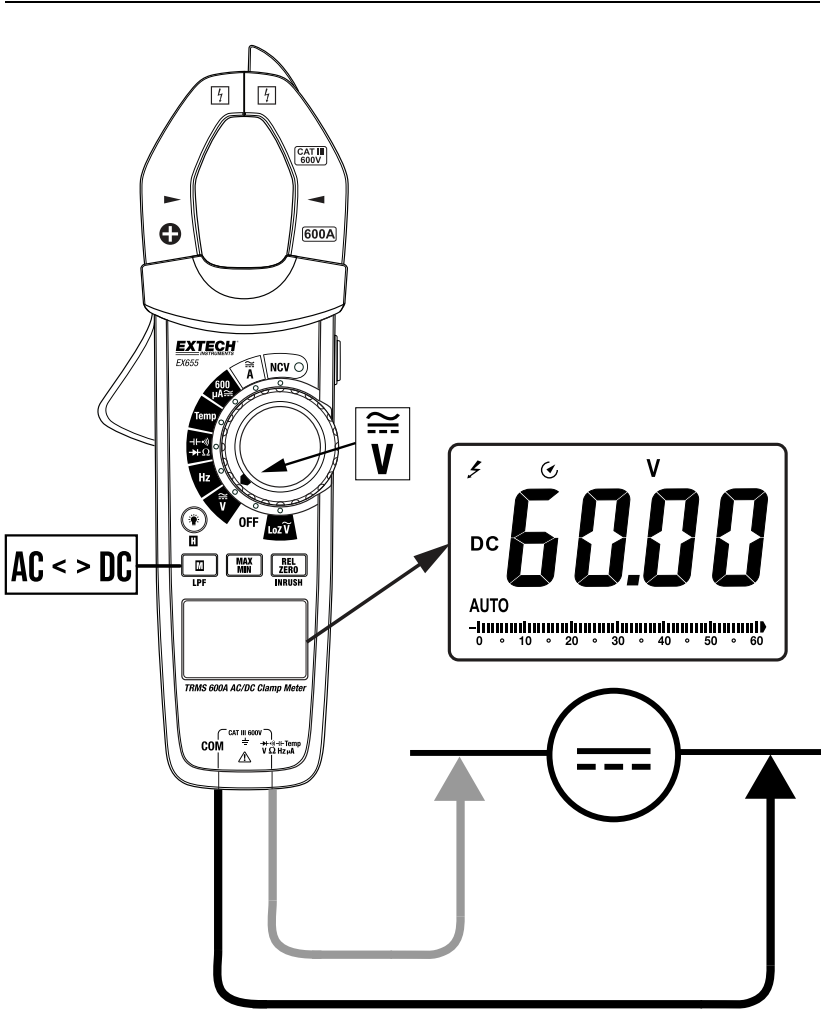

Figure 7.6 DC Voltage Measurements.

7.6 Voltage Measurements (Low Impedance)



For most AC voltage measurements, where 'ghost' voltages are not suspected, a high impedance input circuit (10 M Ω) is used, per the instructions in Section 7.5, above.

However, if voltage is detected on a line that is not energized, a ghost voltage may be present. In this situation, set the function switch to the low impedance position **LoZ** \tilde{V} and measure voltage again.

If the voltage is no longer detected, then the signal was likely a ghost voltage. If the voltage is still present, then a real voltage is present whose source must be investigated, as it can represent a serious safety issue.

In the low impedance mode, the input impedance is approximately 3k Ω .

7.7 Resistance and Continuity Measurements

	WARNING
Read all safety and preparation information in Sections 4 and 7.1 before proceeding.	
	CAUTION
Switch OFF power to the device under test before measuring. Do not test circuits or devices where 60 V DC, 30 V AC, or greater, is present (the voltage alert symbol  appears when such voltages are present).	

NOTE

- **OL** will appear when an open circuit is detected or if the resistance > maximum range.
- Test leads introduce error of approx. 0.1 to 0.2 Ω . Zero the display before measuring by shorting the test leads, pressing the Relative (Zero) button to zero the display, and pressing Relative again to exit the mode.
- If test lead resistance is > 0.5 Ω when shorted, check the connection and inspect the leads for damage.
- Allow time for readings to stabilize when measuring resistance >1M Ω .
- For continuity measurements, the measurement ranges is 600 Ω and open circuit voltage is approximately -3.5 V.

Refer to Figures 7.7 and 7.8, below, for illustrated resistance and continuity measurements.

1. Insert the black test lead banana plug into the negative (COM) meter terminal. Insert the red test lead banana plug into the positive meter terminal.
2. Turn the Function Switch to the Ω position.
3. Use the Mode button to select the Ω icon for resistance or the  icon for continuity.
4. Touch the test probe tips across the circuit or part under test. It is best to disconnect one side of the part under test so that the circuit will not interfere with the resistance reading.
5. For resistance measurements, read the measurement value in the display. The display will indicate the proper decimal point and value. If the reading is out of range, **OL** will appear.
6. For continuity tests, the beeper will sound if the resistance is < 30 Ω . If an open circuit condition is detected, the display will show **OL**.

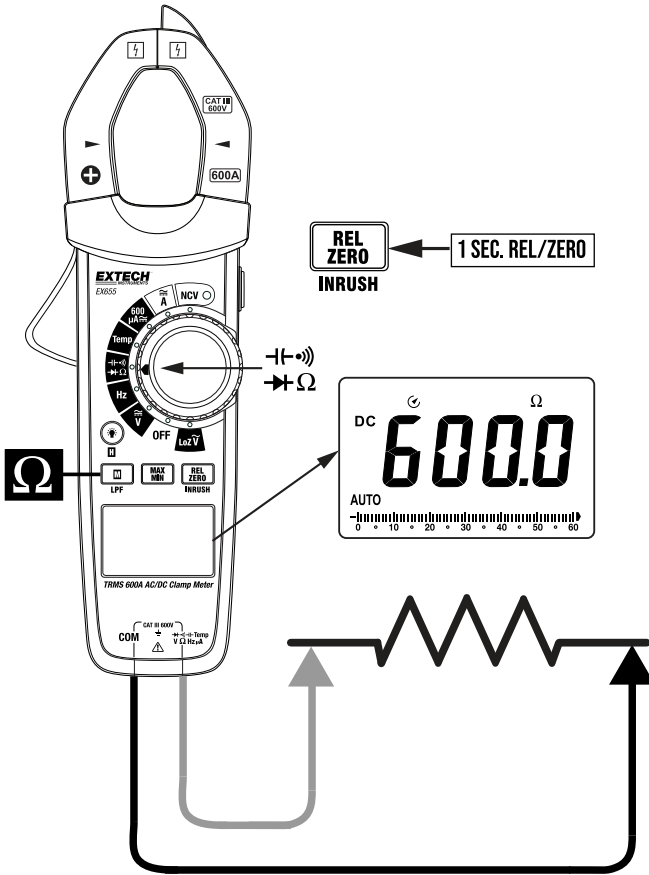

Figure 7.7 Resistance measurements.

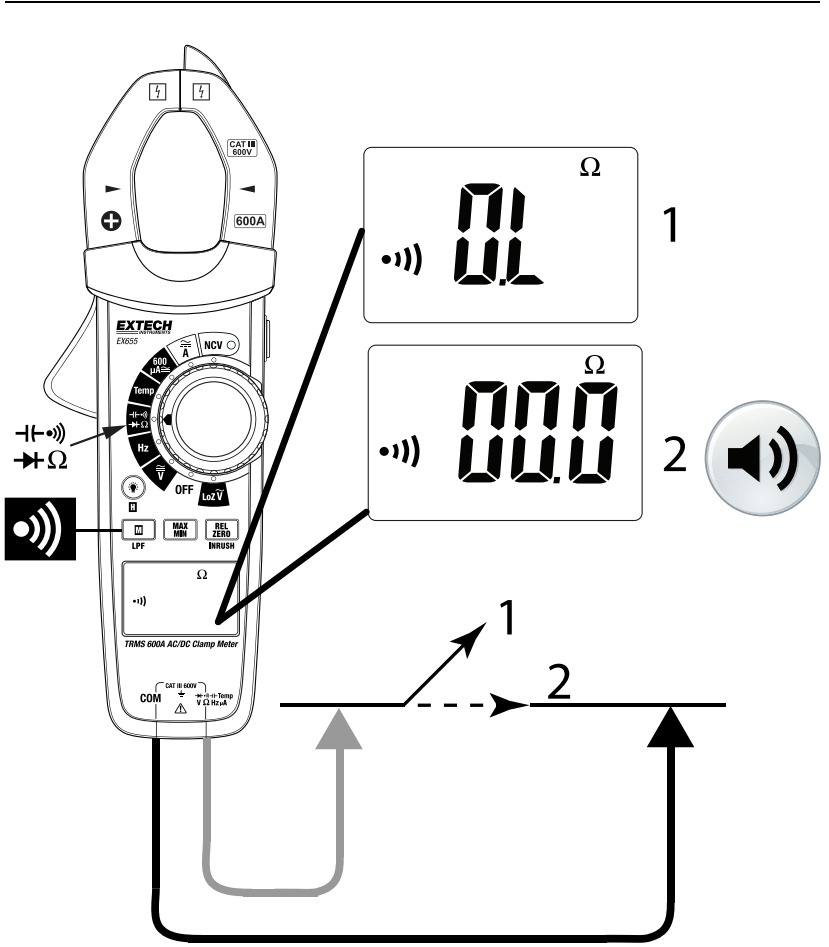

Figure 7.8 Continuity measurements.

7.8 Capacitance Measurements



WARNING

Read all safety and preparation information in Sections 4 and 7.1 before proceeding.



WARNING

To avoid electric shock, remove power to the circuit under test and discharge the capacitor under test before measuring. Do not test on circuits or devices where 60 V DC or 30 V AC is present.

NOTE

- **OL** will appear if a capacitor is short-circuited or if the measured capacitance exceeds the specified range.
- The bar graph is not active in the capacitance mode.
- Capacitance measurements > 600 μF may require several seconds for readings to stabilize.
- For best accuracy, discharge capacitors before taking measurements.
- Use extreme care when handling and working with high voltage capacitors.

Refer to Figure 7.9, below, for illustrated capacitance measurement.

1. Set the function switch to the capacitance position **-f-**.
2. Insert the black test lead banana plug into the negative **COM** terminal and the red test lead banana plug into the positive terminal.
3. Press the Mode button to select the unit of measure symbol **F**.
4. Touch the test probe tips across the part under test.
5. Use the Relative mode (Section 7.13) to compare measurements with a saved reference value.
6. Read the capacitance value on the display. The display will indicate the proper decimal point and value.

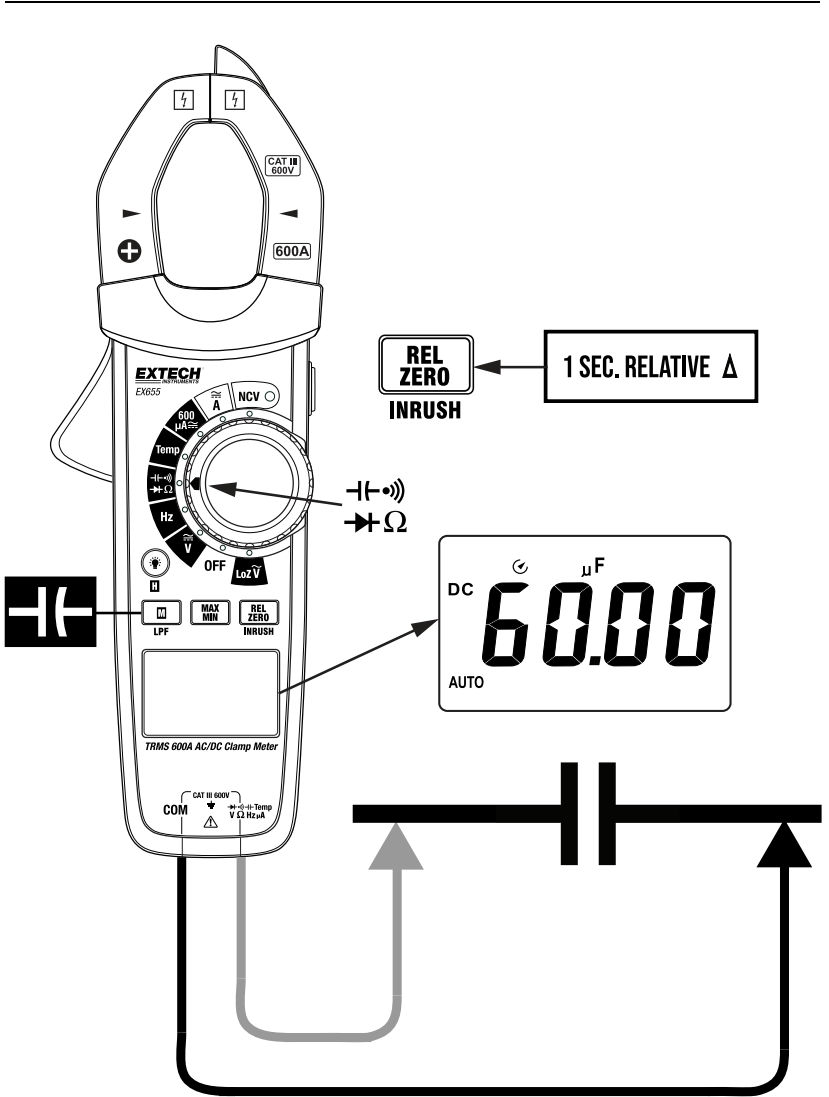

Figure 7.9 Capacitance measurements.

7.9 Electronic Frequency Measurements



WARNING

Read all safety and preparation information in Sections 4 and 7.1 before proceeding.

NOTE

For frequency measurements related to AC electrical measurements, see the Sections above for AC current and voltage measurements.

Sensitivity:

$\leq 100\text{kHz}$: $100\text{mVrms} \leq \text{input amplitude} \leq 20\text{Vrms}$;

100kHz to 1MHz : $200\text{mVrms} \leq \text{input amplitude} \leq 20\text{Vrms}$

Refer to Figure 7.10, below, for illustrated electronic frequency measurement.

1. Insert the black test lead banana plug into the negative (COM) terminal.
Insert the red test lead banana plug into the positive terminal.
2. Turn the Function Switch to the **Hz** position.
3. Touch the test probe tips across the circuit under test.
4. Read the frequency value in the display. The display will indicate the proper decimal point and value.

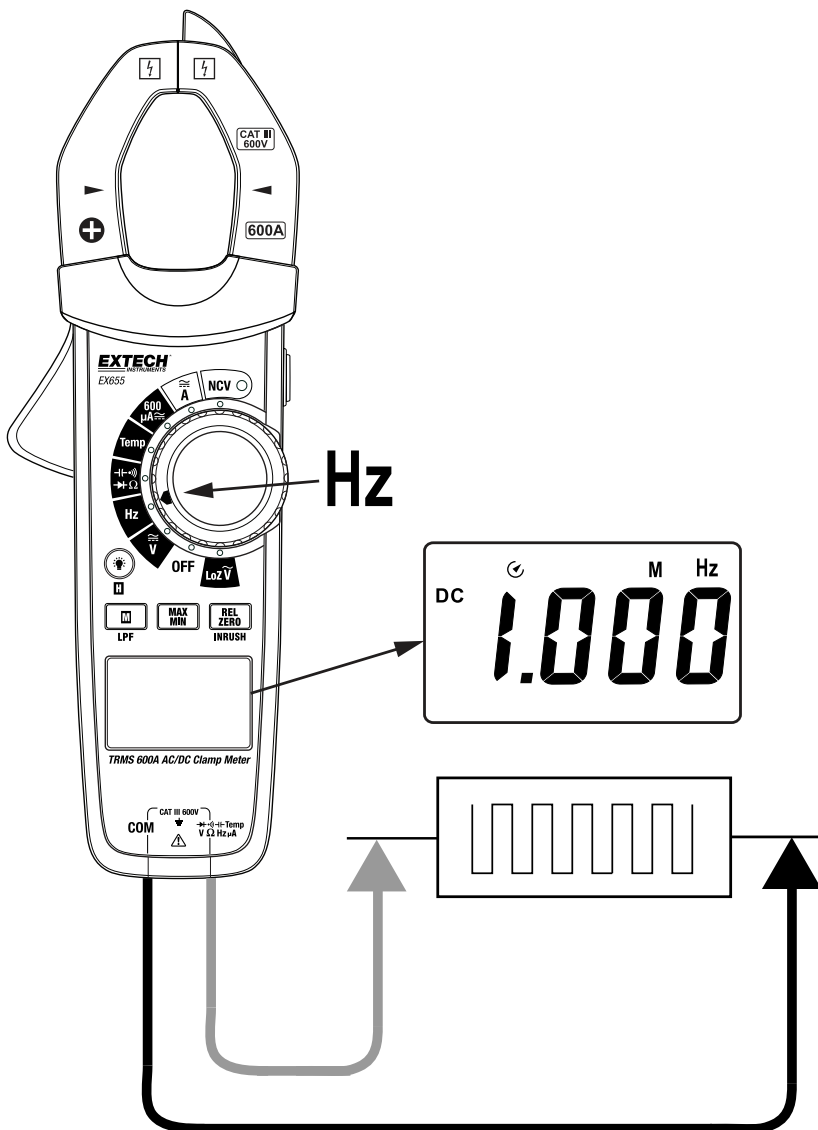





Figure 7.10 Electronic frequency measurements.

7.10 Temperature Measurements

 WARNING
Read all safety and preparation information in Sections 4 and 7.1 before proceeding.
 WARNING
The supplied thermocouple has a limited range, as compared to the specified temperature measurement range of the meter. The supplied thermocouple can measure up to 250°C (482°F) maximum; measuring higher can damage the thermocouple and cause injury.
 CAUTION
For best accuracy, take measurements only when the ambient temperature is in the range of 18 to 28°C (64 to 82°F).

Refer to Figure 7.11, below, for illustrated temperature measurement.

1. Attach the supplied temperature probe to the **COM** and positive terminals, observing correct polarity.
2. Turn the function switch to the **TEMP** position.
3. Use the Mode button to choose the temperature units (°C/°F).
4. Touch the temperature probe tip to the device under test.
5. Read the temperature measurement on the display.

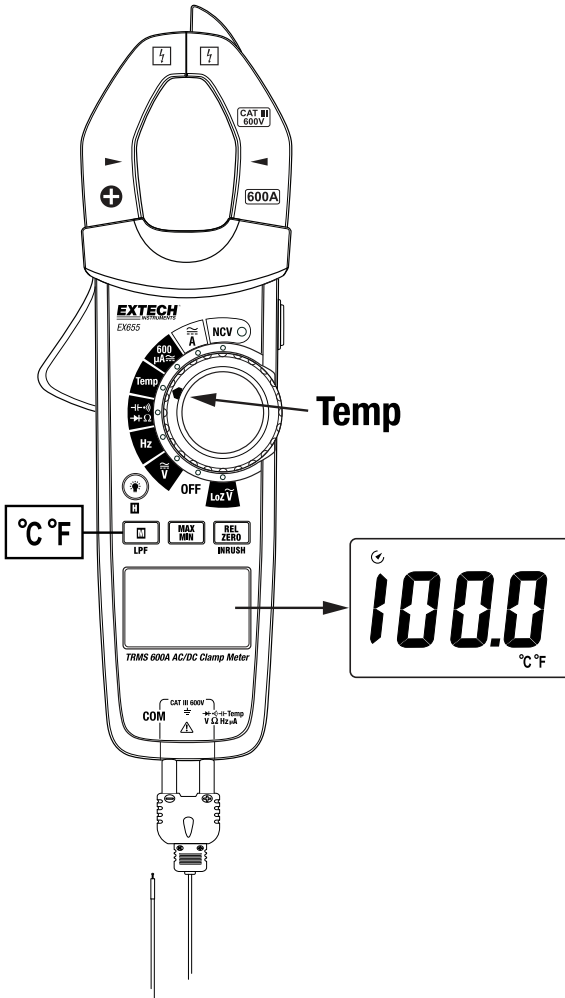



Figure 7.11 Temperature measurements.

7.11 Non-Contact Voltage Detection

	WARNING
Read all safety and preparation information in Sections 4 and 7.1 before proceeding.	
	WARNING
Voltage may be present in a circuit even if the meter does not produce an audible or visual alert. Before use, always verify meter operation on a known, live AC current circuit and ensure that the batteries are fresh.	

When the meter senses an AC Voltage or electromagnetic field > 100 V AC, the following occurs:

- The audible beeper sounds
- The lamp on the NCV function switch position flashes
- The display shows dashes

The greater the detected electrical field strength, the faster the beeper rate, the faster the lamp flashes, and the greater the number of dashes displayed (from 1 to 4). If the meter does not produce an alert, there is still the possibility that voltage is present; **please use caution**.

Refer to Figure 7.12, below, for illustrated non-contact voltage measurement.

1. Turn the function switch to the **NCV** position.
2. **EF** should appear on the display. If **EF** does not appear, stop using the meter and check the batteries.
3. To perform a test, move the tip of the clamp jaws near a source of electrical energy.
4. Note the audible beeping, the flashing lamp, and the displayed dashes when a source of electrical energy is detected.

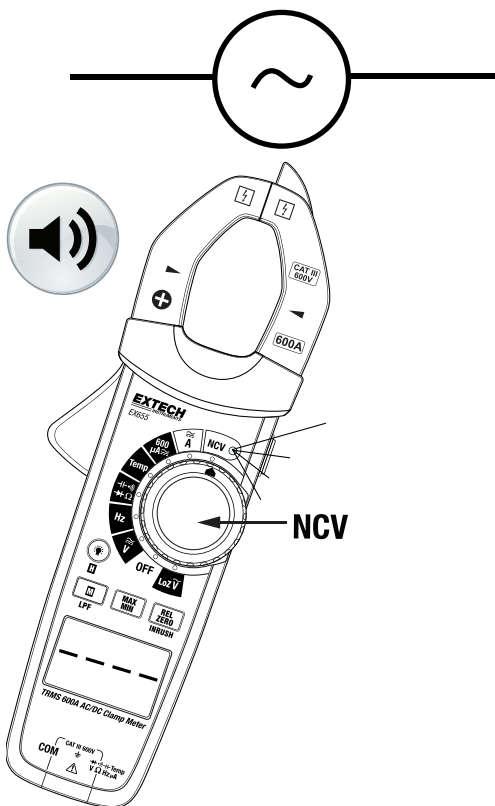

Figure 7.12 Non-contact voltage detection. When voltage is detected the beeper will sound, the NCV lamp will flash, and the display will show dashes.

7.12 Diode Testing



WARNING

Read all safety and preparation information in Sections 4 and 7.1 before proceeding.

Refer to Figure 7.13, below, for illustrated diode measurements.

1. Insert the black test lead banana plug into the negative **COM** terminal and the red test lead banana plug into the positive terminal.
2. Turn the function switch to the diode position **→|**. Use the Mode button to select the diode function (the diode and voltage symbols must be displayed).
3. Touch the test probe tips across the diode or semiconductor junction under test. Note the meter reading.
4. Reverse the red and black leads and test again. Note this reading.
5. The diode or junction can be evaluated as follows:
 - The device under test is good when one reading shows a voltage from 0.500 V to 0.800 V, and the reverse reading shows **OL**.
 - The device is bad (open) if both readings show **OL**.
 - The device is bad (shorted) if both voltage readings are very low, or zero.

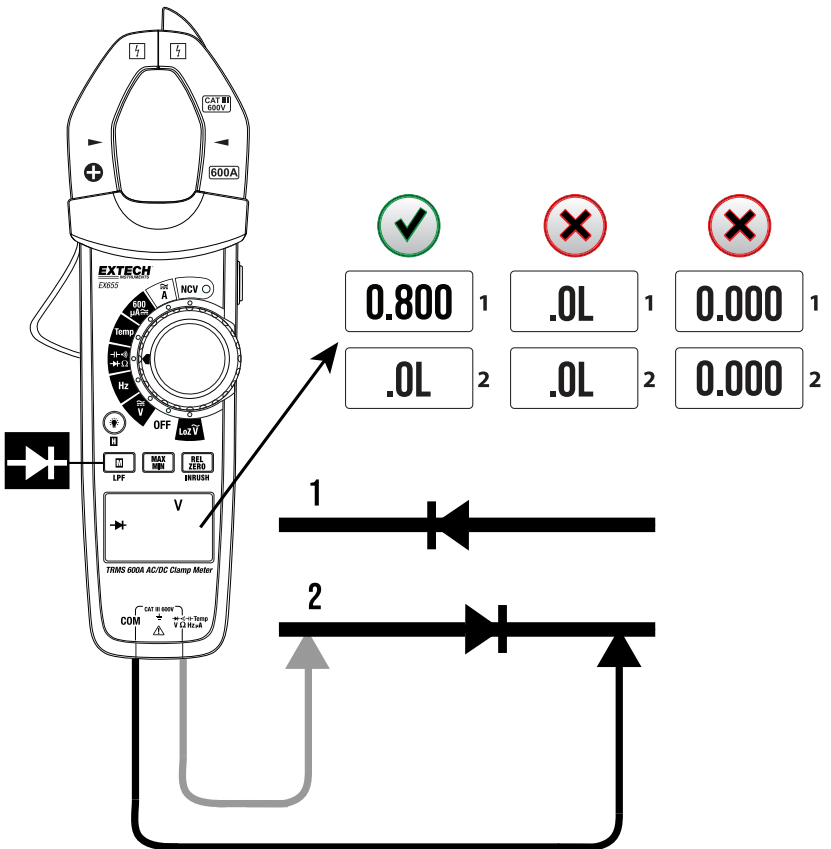

Figure 7.13 Diode testing. Measure the diode in both polarity orientations and compare the results with the three test result examples shown in this diagram. In the first test result column (under the check mark), the device is good since voltage is detected in only one orientation. In the second test result column, the device is bad because both measurements indicate OL. In the third test result column, the device is bad because no voltage is detected in either orientation.

7.13 Relative (Zero) Mode

In Relative mode a reference measurement is saved and subtracted from subsequent readings. Relative mode is available for voltage, current, and capacitance measurements.

Relative mode is especially useful for zeroing the display before measuring DC current with the clamp and before measuring low resistance with the test leads.

1. Press the Relative button to store a reference measurement, the display will zero. The delta symbol Δ is displayed while the relative mode is active.
2. Take measurements and note that the displayed reading represents the actual measurement minus the saved reference measurement.
3. Press the Relative button again to exit, the delta symbol will switch OFF.

7.14 MAX-MIN Measurement Capture

In MAX-MIN mode, the meter captures and displays the maximum and minimum readings, updating the readings only when higher or lower values are registered.

This mode is available in the Voltage (AC and DC), Current (AC and DC), Resistance, and Temperature modes.

1. Press the MAX MIN button to start recording.
2. The **MAX** icon will appear and the displayed reading will represent the highest reading.
3. Press the button again. The **MIN** icon will appear and the displayed reading will represent the lowest reading.
4. Continue to use the button to toggle the MAX and MIN readings.
5. To exit this mode, and to reset the MAX MIN memories, long press the button (the **MAX** and **MIN** icons will switch OFF).

8 Maintenance



CAUTION

To avoid electric shock, remove the test leads, disconnect the meter from the circuit under test, and switch OFF the meter before accessing the battery compartment. Never use the meter with an opened battery compartment or if the meter housing is open or damaged.

8.1 Battery Replacement

When the battery needs to be replaced, the low battery symbol  will appear.

1. Put the function switch in the OFF position and remove the test leads.
2. Remove the Phillips screw that secures the rear battery compartment.
3. Remove the battery compartment cover and replace the three (3) 1.5 V 'AAA' batteries, observing correct polarity.
4. Reassemble the battery compartment before use.

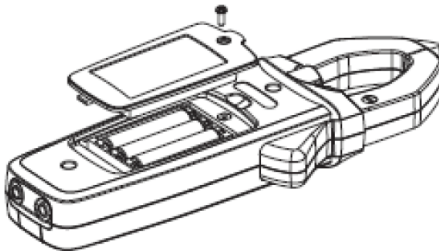

Figure 8.1 Replacing the batteries.



Never dispose of used batteries or rechargeable batteries in household waste. As consumers, users are legally required to take used batteries to appropriate collection sites, the retail store where the batteries were purchased, or wherever batteries are sold. **Disposal:** Do not dispose of this instrument in household waste. The user is obligated to take end-of-life devices to a designated collection point for the disposal of electrical and electronic equipment.

8.2 Cleaning and Storage

With the meter OFF, wipe the case with a damp cloth and mild detergent to clean; do not use abrasives or solvents.

Store the meter in a protective case or in the original packaging. Remove the batteries and store separately if the meter is to be stored for an extended period of time.

9 Specifications

9.1 General Specifications

Display	6000 count multifunction LCD
Polarity	Positive assumed; negative indicated
Over-range indication	OL displayed
Display update rate	3 refreshes per second
Clamp sensor type	Hall Effect
Clamp test position error	Additional error of $\pm 1.0\%$ of reading applies when tested conductor is not positioned at the centre of the clamp area
Jaw opening	30 mm (1.2 in.)
Electromagnetic field interference	Can cause unstable or inaccurate readings
Maximum voltage	600 V AC DC applied to any terminal
Low battery indication	Battery symbol 
Automatic power OFF	After 20 minutes of inactivity
Operating conditions	0 to 30°C (32 to 86°F); 80% RH maximum 30 to 40°C (86 to 104°F); 75% RH maximum 40 to 50°C (104 to 122°F); 45% RH maximum
Storage conditions	-20 to 60°C (-4 to 140°F); 80% RH max. (batteries removed)
Operating altitude	2000 m (6562 ft.)
Battery power	Three (3) x 1.5 V 'AAA' batteries
Weight	270 g (9.5 oz.) with batteries
Dimensions	75 x 223 x 40 mm (2.9 x 8.7 x 1.6 in.)
Safety rating and compliance	EN61010-1, EN61010-2-032, and EN61010-2-033 CAT III 600 V Pollution Degree 2
EMC	EN61326-1
Shock and vibration	MIL-PRF-28800F (5 to 55 Hz, 3 g, maximum)
Drop protection	1 m (3.3 ft.)
For indoor use only	

9.2 Measurement Specifications

Accuracy is given as \pm (% of reading + least significant digits) at 23°C (73.4°F) \pm 5°C (9°F) and relative humidity < 80%. Accuracy is specified for a period of one year after calibration.

- Temperature coefficient is 0.1 x specified accuracy / 1°C (1.8°F), < 18°C (64.5°F), > 28°C (82.4°F)
- AC V and AC A measurements are AC coupled, True RMS; For all waveforms, other than sine waves, the specified accuracy is adjusted as shown below.
 - Crest Factor 1 to 2, specified accuracy increases by 3%.
 - Crest Factor 2 to 2.5, specified accuracy increases by 5%.
 - Crest Factor 2.5 to 3, specified accuracy increases by 7%.

FUNCTION	RANGE	RESOLUTION	ACCURACY	OVERLOAD PROTECTION
AC Current	6.000 A	0.001 A	\pm (2.5% + 30 digits)	600 A
	60.00 A	0.01 A	\pm (2.5% + 5 digits)	
	600.0 A	0.1 A		
Notes: True RMS current applicable from 10 to 100% of range; Frequency response: 50 to 60 Hz. Inrush current accuracy not specified.				
AC Current (μ A)	600 μ A	0.1 μ A	\pm (1.2% + 5 digits)	600 V AC
DC Current	60.00 A	0.01 A	\pm (2.5% + 5 digits)	600 A DC
	600.0 A	0.1 A		
DC Current (μ A)	600 μ A	0.1 μ A	\pm (1.0% + 2 digits)	600 V DC
AC Voltage	6.000 V	0.001 V	\pm (1.2% + 5 digits)	600 V AC
	60.00 V	0.01 V		
	600.0 V	0.1 V		
Notes: True RMS voltage applicable from 10 to 100% of range; Input impedance 10 M Ω or greater. Frequency response: 40 to 400 Hz.				
AC Voltage with Low Pass Filter (LPF)	600.0 V	0.1 V	\pm (6.5% + 5 digits)	600 V AC

AC Voltage in Low Impedance mode (LoZ)	600.0 V	0.1 V	$\pm (1.5\% + 5 \text{ digits})$	600 V AC
Notes: Input impedance in low impedance mode: 3 k Ω approximately. Frequency response: 40 to 400 Hz.				
DC Voltage	600.0 mV	0.1 mV	$\pm (1.0\% + 5 \text{ digits})$	600 V DC
	6.000 V	0.001 V	$\pm (0.8\% + 1 \text{ digit})$	
	60.00 V	0.001 V	$\pm (0.8\% + 3 \text{ digits})$	
	600.0 V	0.01 V		
Note: Input impedance: 10 M Ω or greater				
Resistance	600.0 Ω	0.1 Ω	$\pm (1.2\% + 2 \text{ digits})$	600 V AC DC
	6.000 k Ω	0.001 k Ω	$\pm (1.0\% + 2 \text{ digits})$	
	60.00 k Ω	0.01 k Ω		
	600.0 k Ω	0.1 k Ω		
	6.000 M Ω	0.001 M Ω	$\pm (1.2\% + 2 \text{ digits})$	
	60.00 M Ω	0.01 M Ω	$\pm (1.5\% + 5 \text{ digits})$	
Continuity	600.0 Ω	0.1 Ω	$\pm (1.2\% + 2 \text{ digits})$	600 V AC DC
Capacitance	60.00 nF	0.01 nF	$\pm (4.0\% + 25 \text{ digits})$	600 V AC DC
	600.0 nF	0.1 nF	$\pm (4.0\% + 5 \text{ digits})$	
	6.000 μ F	0.001 μ F		
	60.00 μ F	0.01 μ F		
	600.0 μ F	0.1 μ F		
	6000 μ F	1 μ F	$\pm (10\%)$	
	60.00 mF	0.01 mF	Not specified	
Frequency	10 Hz to 1 MHz	0.01 Hz to 1 kHz	$\pm (0.1\% + 3 \text{ digits})$	600 V AC DC

Sensitivity: $\leq 100\text{kHz}$: $100\text{mVrms} \leq \text{input amplitude} \leq 20\text{Vrms}$; 100kHz to 1MHz : $200\text{mVrms} \leq \text{input amplitude} \leq 20\text{Vrms}$				
Temperature	-40 to +40°C*	1°C	$\pm (3.0\% + 5 \text{ digits})$	600 V AC DC
	40 to 400°C*		$\pm (2.0\% + 5 \text{ digits})$	
	100 to 1000°C*			
	-40 to +104°F*	1°F	$\pm (3.0\% + 10 \text{ digits})$	600 V AC DC
	104 to 752°F*		$\pm (2.0\% + 10 \text{ digits})$	
	752 to 1832°F*			
<p>* WARNING: The supplied thermocouple has a limited range, as compared to the measurement range of the meter. The supplied thermocouple can measure up to 250°C (482°F) maximum; measuring higher can damage the thermocouple and cause injury.</p> <p>Temperature accuracy notes:</p> <p>Temperature accuracy specification does not include the accuracy of the temperature probe.</p> <p>Accuracy specification assumes the surrounding temperature is stable to $\pm 1^\circ\text{C}$ (1.8°F).</p> <p>For ambient temperature changes of $\pm 5^\circ\text{C}$ ($\pm 9^\circ\text{F}$), the specified accuracy requires 2 hours of stabilization.</p>				
Diode Test	3 V	0.001 V	Silicon PN junction 0.5 to 0.8 V (typically)	600 V AC DC
Non-Contact Voltage Detector (NCV)	$\geq 100 \text{ V AC RMS}$	n/a	Detection distance: $\leq 10\text{mm}$	n/a

10 Customer Support

Local Telephone Support List	https://support.flir.com/contact
Return Material Authorization (RMA)	https://customer.flir.com/Home
Customer Support	https://support.flir.com/ContactService
Technical Support	https://support.flir.com

FLIR Systems, Inc. offers calibration and repair services for the Extech brand products we sell. We offer NIST traceable calibration for most of our products.

11 Limited 3–Year Warranty

FLIR Systems, Inc. warrants this Extech brand instrument to be free of defects in parts and workmanship for three (3) years from date of purchase. To view the full warranty, please visit the site below.

<https://www.extech.com/support/warranties>

Website

<http://www.flir.com>

Customer support

<http://support.flir.com>

Copyright

© 2025, FLIR Systems, Inc. All rights reserved worldwide.

Disclaimer

Specifications subject to change without further notice. Models and accessories subject to regional market considerations. License procedures may apply. Products described herein may be subject to US Export Regulations. Please refer to exportquestions@flir.com with any questions.

Publ. No.: NAS100234
Release: AA
Commit: 104890
Head: 105182
Language: en-GB
Modified: 2025-05-07
Formatted: 2025-05-19

